



SERIES: **APM**

TOHIO

PATENTED

INTERCHANGE: ISO 16028 and NFPA T3.20.15 (HTMA)

MAIN APPLICATIONS

- Mobile construction equipment
- Agricultural equipment
- Hydraulic tools
- Industrial equipment
- Vehicles

The "APM" male flat face coupling series is the Stucchi solution for the manual connection with residual pressure in the circuit. The couplings have a triple valve system: double internal pressure release valve and the flat face valve.

This system easily allows the connection of couplings with the presence of high internal residual pressure without fluid loss. Based on this main feature, "APM" couplings are the ideal solution to hydraulic applications where there is the requirement to connect the circuit with internal residual pressure.



Stucchi[®]

A CONSTANT FLOW OF SOLUTIONS

TECHNICAL FEATURES AND OPTIONS

- Interchangeability: ISO 16028 (from size 10 to 25) HTMA (size 10)
- Valve system: Flat face
- Mechanical connection: Locking balls
- Connection system: Push to connect
- Disconnection system: Pulling back the sleeve of female
- Connection with residual pressure: Only in the APM male coupling, the female coupling must be to drain
- Disconnection with residual pressure: Not allowed
- Threads available: BSP, NPT, SAE
- Threads on request: Metrics DIN, ORFS or other
- Material: High grade carbon steel
- Surface treatment: CrIII zinc plated
- Internal springs: C72 steel
- Seals: standard in NBR (Nitrile)
- Anti-extrusion rings: PTFE
- On request: different materials and seals

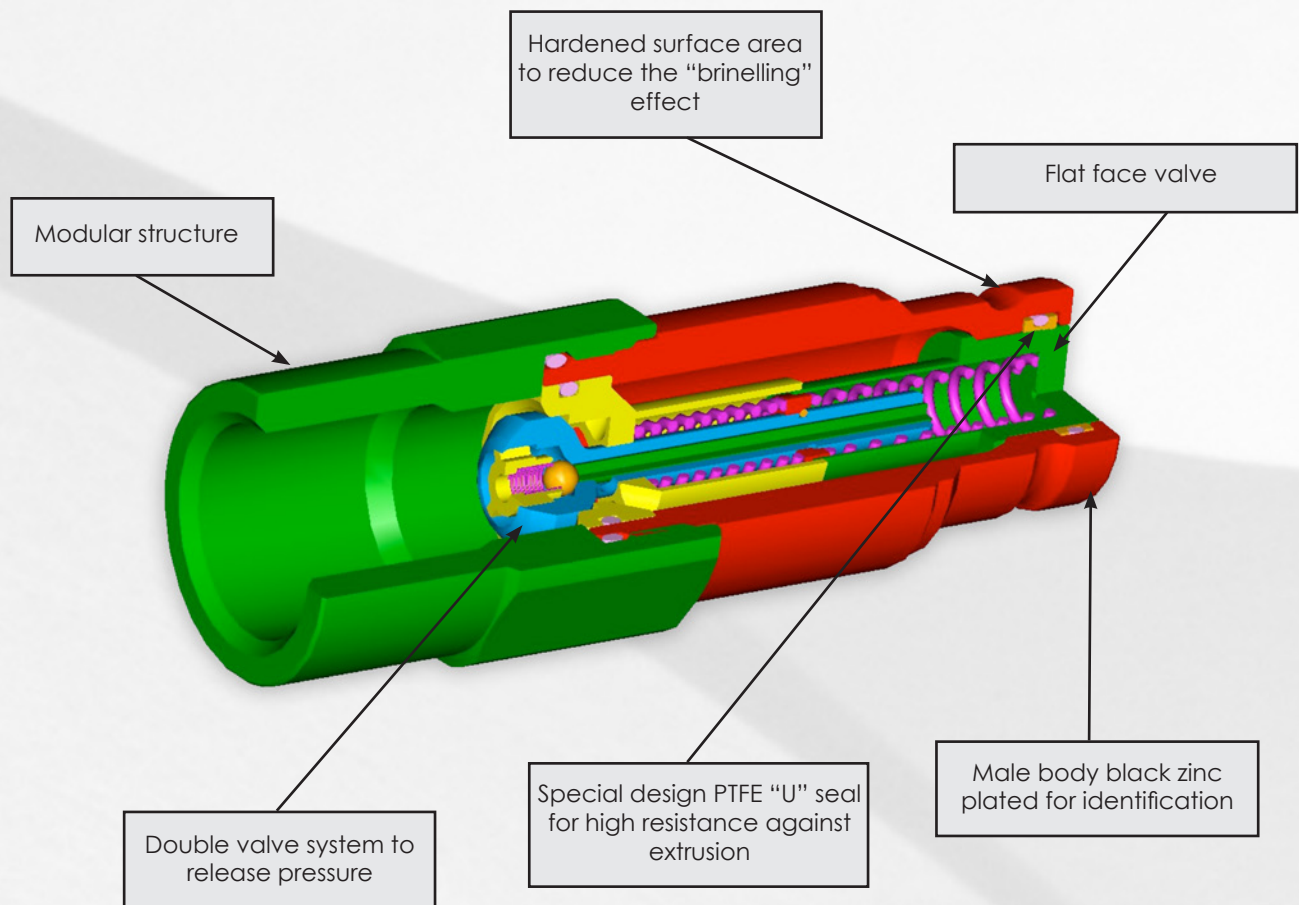

BENEFITS

- Flat face is easy to clean, helping to reduce the inclusion of contamination to the hydraulic circuit.
- Minimal fluid loss during connection / disconnection, reducing fluid loss to the environment.
- Minimal air inclusion during connection / disconnection, enhancing correct function of the circuit.
- Internal pressure release valve system allows manual connection with high internal residual pressure.
- The modular design allows flexibility with the range of port configurations.
- Good resistance at impulse pressures.
- Compact slim design.
- Safe and simple to use.

HOW TO USE

- Before to couple clean the flat mating surface of quick coupling to avoid the inclusion of dirty in the circuit.
- To couple push the male half towards the female half or vice versa.
- After connection turn the external sleeve to engage lock function, to prevent accidental disconnection.
- To uncouple turn the external sleeve until the sleeve lock groove corresponds with the safety lock ball and pull back the sleeve.

WARNING!

- Do not couple-uncouple with flow in the circuit. Connection is allowed only with residual pressure trapped in the circuit.
- Do not couple-uncouple when the temperature inside of the circuit is higher than 80 °C (176 °F).
- When the couplings are disconnected, it is suggested to use the protection caps. The protection caps of "FIRG-A" series are suitable with male couplings "APM".
- It is important maintain a good cleanliness of circuit because a high grade of dirty could compromise the function of the internal double valve.

PERFORMANCE

Description	Size	ISO Size	Rated Flow		Max. flow suggested		Connect force° without pressure		Disconnect° force		Spillage *
			l/min	GPM	l/min	GPM	N	lbf	N	lbf	
	Inch	mm									ml
APM9	3/8	10,0	23	6,10	46	12,19	165	37,13	40	9,00	0,016
APM13	1/2	12,5	45	11,93	90	23,85	190	42,75	70	15,75	0,010
APM15	5/8	16,0	74	19,61	148	39,22	160	36,00	50	11,25	1,200
APM17	3/4	19,0	100	26,50	200	53,00	260	58,50	80	18,00	0,180
APM21	1	25,0	189	50,09	378	100,17	300	67,50	90	20,25	0,180
APM30	1-1/2	-	288	76,32	750	198,75	440	99,00	80	18,00	0,400

Description	Max. operating pressure				Burst pressure				Max. residual pressure	
	Coupled °		Male		Coupled °		Male			
	MPa	psi	MPa	psi	MPa	psi	MPa	psi	MPa	psi
APM9	35	5075	35	5075	100	14500	120	17400	30	4350
APM13	33	4785	33	4785	100	14500	120	17400	30	4350
APM15	33	4785	33	4785	100	14500	120	17400	30	4350
APM17	33	4785	33	4785	100	14500	120	17400	25	3625
APM21	30	4350	30	4350	80	11600	100	14500	25	3625
APM30	27	3915	27	3915	80	11600	100	14500	20	2900

* Spillage is an indicative value of the fluid loss per couple-uncouple cycle.

° Tested with female couplings "A" series

THEORETICAL CALCULATION OF CONNECT FORCE WITH RESIDUAL PRESSURE:

$$F_p (N) = F_i + (P_m \times 5)$$

F_i = Connection force without residual pressure (N)

P_m = Residual pressure in the male coupling (MPa)

EXAMPLE:

To connect the male coupling APM13 with 20 Mpa of residual pressure, it is necessary the following force:

$$F_p = F_i + (P_m \times 5) = 190 + (20 \times 5) = 290 \text{ N}$$

• Temperature range:

- Standard seals NBR (Nitrile): from -20 °C to +100 °C (from -4 °F to +212 °F).

• Tests:

- The couplings have been tested at impulse with max. operating pressure for 100.000 impulses in according with ISO 7241-2.

PRESSURE DROP

TESTS ESEGUITI IN CONFORMITA' A ISO 7241-2
 TESTS IN ACCORDANCE WITH ISO 7241-2

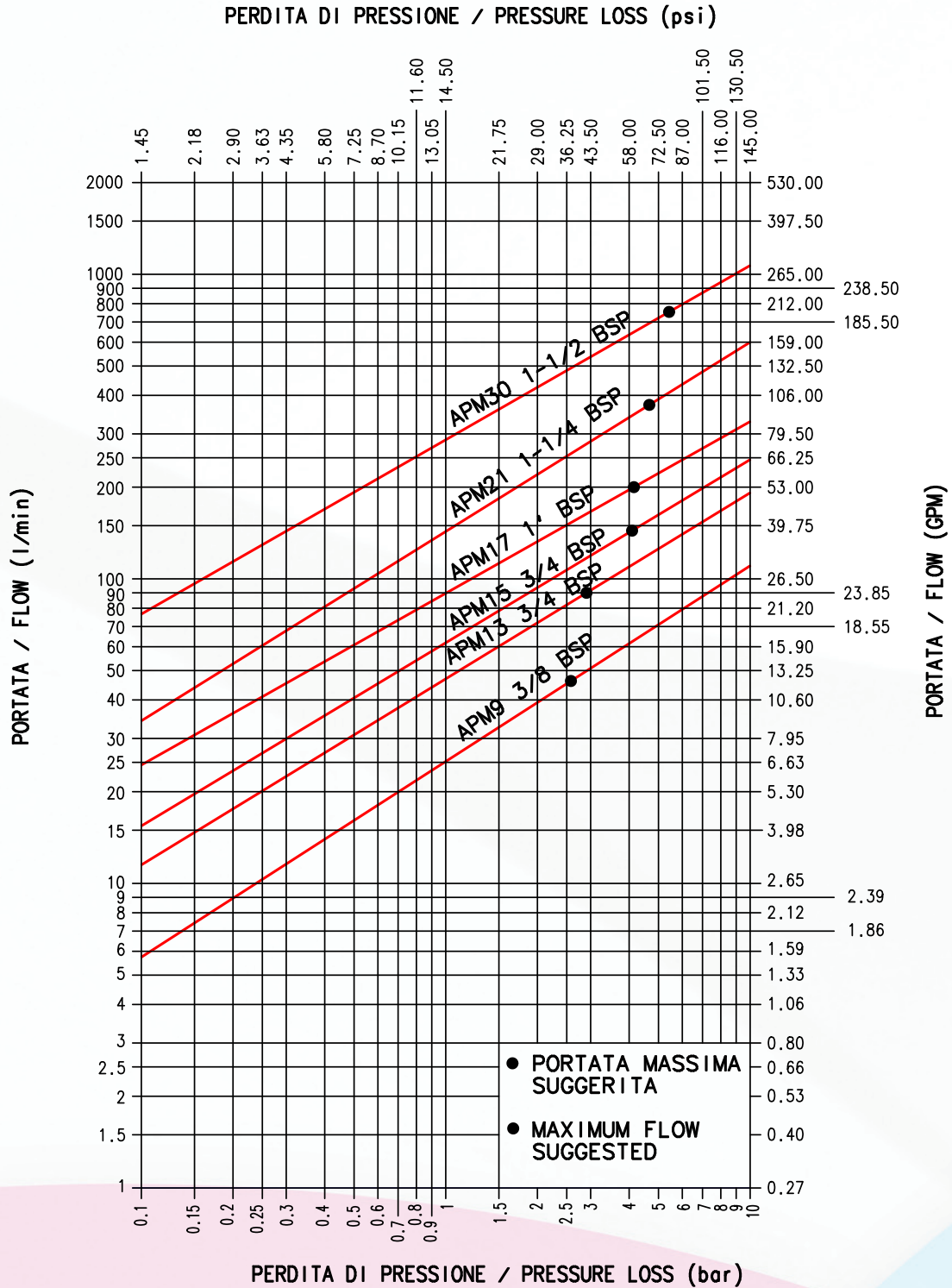

FLUIDO: OLIO ISO VG32
 TEMPERATURA: 40°C
 VISCOSITA': 28.8-35.2 mm²/s

FLUID: OIL ISO VG32
 TEMPERATURE: 40°C
 VISCOSITY: 28.8-35.2 mm²/s

OVERALL DIMENSIONS

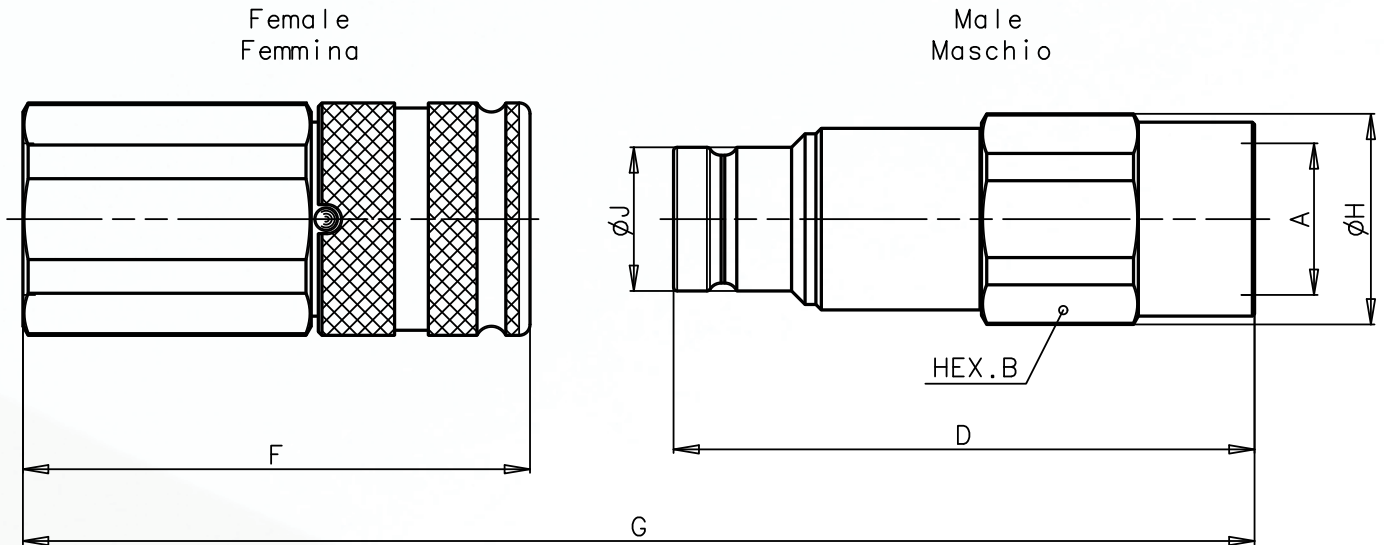

FEMALE BSPB THREAD (DIN 3852)

Description	A	Unit	B	C	D	E	F	G	H	I	J	Unit	Weight	
													Male	Female
APM9 3/8 BSP	3/8	mm Inch	27 1,06	-	80 3,15	-	-	(F+D)-16 (F+D)-0,630	29 1,14	-	19,7 0,78	Kg lb	0,197 0,43	-
APM9 1/2 BSP	1/2	mm Inch	27 1,06	-	82,5 3,25	-	-	(F+D)-16 (F+D)-0,630	29 1,14	-	19,7 0,78	Kg lb	0,195 0,43	-
APM13 1/2 BSP	1/2	mm Inch	36 1,42	-	91 3,58	-	-	(F+D)-17,3 (F+D)-0,681	38,5 1,52	-	24,5 0,96	Kg lb	0,408 0,90	-
APM13 3/4 BSP	3/4	mm Inch	36 1,42	-	93,5 3,68	-	-	(F+D)-17,3 (F+D)-0,681	38,5 1,52	-	24,5 0,96	Kg lb	0,404 0,89	-
APM15 3/4 BSP	3/4	mm Inch	36 1,42	-	95 3,74	-	-	(F+D)-17,6 (F+D)-0,693	38,5 1,52	-	27 1,06	Kg lb	0,426 0,94	-
APM17 1 BSP	1	mm Inch	46 1,81	-	108,5 4,27	-	-	(F+D)-22 (F+D)-0,866	49,8 1,96	-	30 1,18	Kg lb	0,750 1,65	-
APM21 1-1/4 BSP	1-1/4	mm Inch	55 2,17	-	123,5 4,86	-	-	(F+D)-23 (F+D)-0,906	59,8 2,35	-	36 1,42	Kg lb	1,160 2,56	-
APM30 1-1/2 BSP	1-1/2	mm Inch	70 2,76	-	146,9 5,78	-	-	(F+D)-28,6 (F+D)-1,126	75,8 2,98	-	57 2,24	Kg lb	2,580 5,69	-

OVERALL DIMENSIONS

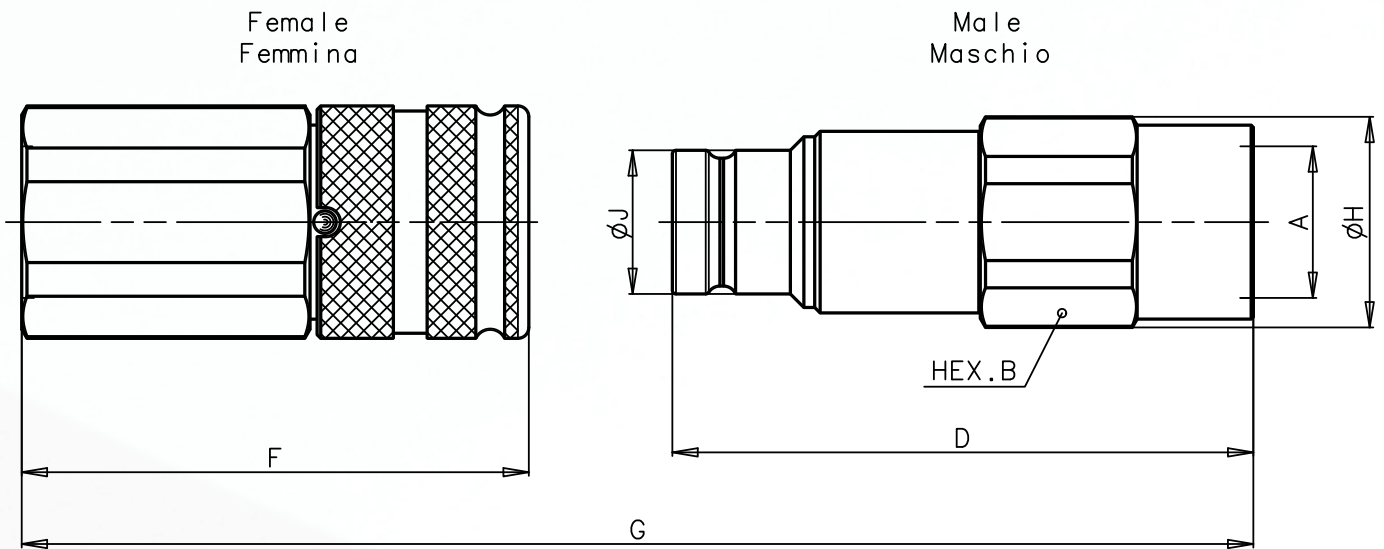

FEMALE NPT THREAD (ANSI B.1.20.3)

Description	A	Unit	B	C	D	E	F	G	H	I	J	Unit	Weight	
													Male	Female
APM9 3/8 NPT	3/8	mm Inch	27 1,06	- -	80 3,15	- -	- -	(F+D)-16 (F+D)-0,630	29 1,14	- -	19,7 0,78	Kg lb	0,210 0,46	- -
APM9 1/2 NPT	1/2	mm Inch	27 1,06	- -	82,5 3,25	- -	- -	(F+D)-16 (F+D)-0,630	29 1,14	- -	19,7 0,78	Kg lb	0,205 0,45	- -
APM13 1/2 NPT	1/2	mm Inch	36 1,42	- -	91 3,58	- -	- -	(F+D)-17,3 (F+D)-0,681	38,5 1,52	- -	24,5 0,96	Kg lb	0,430 0,95	- -
APM13 3/4 NPT	3/4	mm Inch	36 1,42	- -	93,5 3,68	- -	- -	(F+D)-17,3 (F+D)-0,681	38,5 1,52	- -	24,5 0,96	Kg lb	0,415 0,91	- -
APM15 3/4 NPT	3/4	mm Inch	36 1,42	- -	95 3,74	- -	- -	(F+D)-17,6 (F+D)-0,693	38,5 1,52	- -	27 1,06	Kg lb	0,435 0,96	- -
APM17 1 NPT	1	mm Inch	46 1,81	- -	108,5 4,27	- -	- -	(F+D)-22 (F+D)-0,866	49,8 1,96	- -	30 1,18	Kg lb	0,760 1,68	- -
APM21 1-1/4 NPT	1-1/4	mm Inch	55 2,17	- -	123,5 4,86	- -	- -	(F+D)-23 (F+D)-0,906	59,8 2,35	- -	36 1,42	Kg lb	1,200 2,65	- -
APM30 1-1/2 NPT	1-1/2	mm Inch	70 2,76	- -	146,9 5,78	- -	- -	(F+D)-28,6 (F+D)-1,126	75,8 2,98	- -	57 2,24	Kg lb	2,595 5,72	- -

OVERALL DIMENSIONS

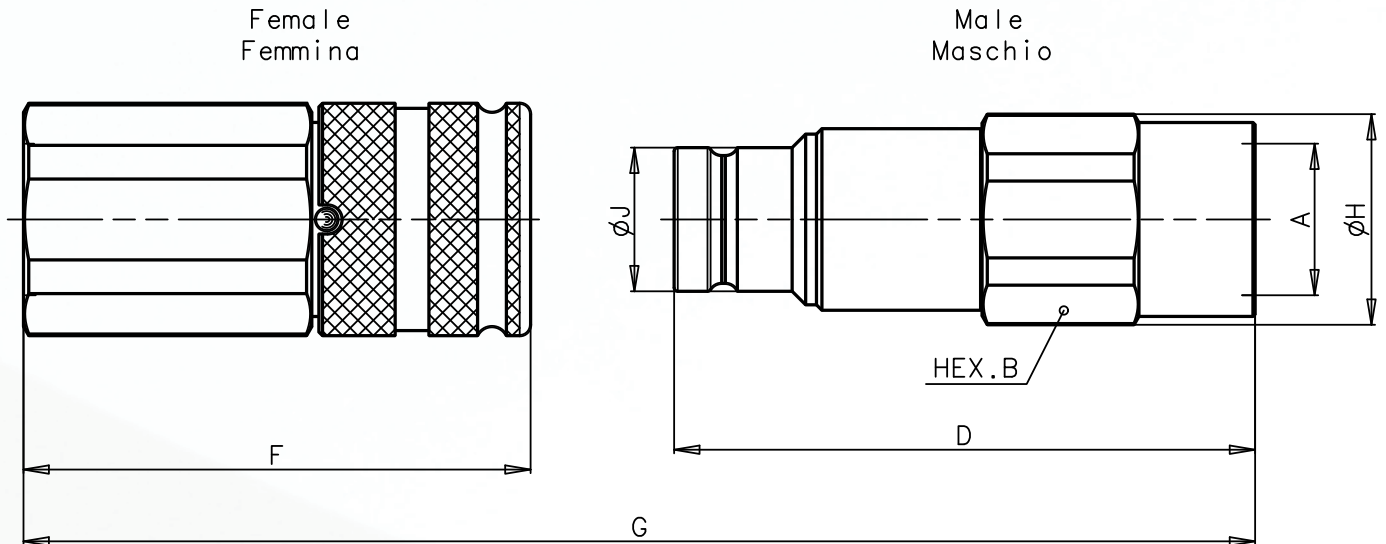

FEMALE SAE THREAD (SAE J1926-1)

Description	A	Unit	B	C	D	E	F	G	H	I	J	Unit	Weight	
													Male	Female
APM9 1/2 SAE	3/4- 16UNF	mm Inch	27 1,06	- -	82,5 3,25	- -	- -	(F+D)-16 (F+D)-0,630	29 1,14	- -	19,7 0,78	Kg lb	0,205 0,45	- -
APM13 5/8 SAE	7/8- 14UNF	mm Inch	36 1,42	- -	91,0 3,58	- -	- -	(F+D)-17,3 (F+D)-0,681	38,5 1,52	- -	24,5 0,96	Kg lb	0,413 0,91	- -
APM13 3/4 SAE	1-1/16- 12UN	mm Inch	36 1,42	- -	93,5 3,68	- -	- -	(F+D)-17,3 (F+D)-0,681	38,5 1,52	- -	24,5 0,96	Kg lb	0,400 0,88	- -
APM15 3/4 SAE	1-1/16- 12UN	mm Inch	36 1,42	- -	95,0 3,74	- -	- -	(F+D)-17,6 (F+D)-0,693	38,5 1,52	- -	27 1,06	Kg lb	0,425 0,94	- -
APM17 1 SAE	1-5/16- 12UN	mm Inch	46 1,81	- -	108,5 4,27	- -	- -	(F+D)-22 (F+D)-0,866	49,8 1,96	- -	30 1,18	Kg lb	0,755 1,66	- -
APM21 1-1/4 SAE	1-5/8- 12UN	mm Inch	55 2,17	- -	123,5 4,86	- -	- -	(F+D)-23 (F+D)-0,906	59,8 2,35	- -	36 1,42	Kg lb	1,185 2,61	- -
APM30 1-1/2 SAE	1-7/8- 12UN	mm Inch	70 2,76	- -	146,9 5,78	- -	- -	(F+D)-28,6 (F+D)-1,126	75,8 2,98	- -	57 2,24	Kg lb	2,580 5,69	- -